

K'hillah

What Goes in each Box or Kit:

Minimum Container Size for the entire module: 9.5" x 12" x 2" (your container may need to be bigger)
This will allow for paper to lay (or stand) flat with the other materials stacked neatly on top.

NOTES:

- Titles of resource documents are on the top of the page; Resource Sheet Labels (ex: Resource Sheet 1) are on the bottom, right of the page.
- Links to suggestions for various supplies are in the chart below (pages 6-7).
- Shorthand: K = K'hillah; W = Week (W1 = Week 1, W2 = Week 2); QR = QR Code

Week 1

- QR code card, printed on cardstock, leading to the explanation video for children
- Recipe Card, printed on cardstock (see Prep Instructions)
- Recipe ingredients each in a separate bag (see Prep Instructions)
 - 4 tablespoons of unsweetened baking cocoa (Dutched/Dutch processed preferred)
 - 4 tablespoons of sugar (OR sugar-substitute such as Stevia)
 - 2 pinches of salt
 - 2/3 cup of powdered nonfat milk
 - A handful of mini marshmallows
- 5 zipper-seal bags (snack size)
 - 1 for the baking cocoa
 - 1 for the sugar (OR sugar-substitute like Stevia)
 - 1 for the salt
 - 1 for the powdered nonfat milk
 - 1 for the mini marshmallows

Prep Instructions:

- Find **K MODULE KIT LABEL Resource Sheet 39** on page 8 and print onto cardstock or regular paper. Cut the sheet into 4 individual box/kit labels and attach 1 label to the outside of each of the distribution containers to each learner.
- Find **K QR W1 RESOURCE SHEET 40** on page 9 and print onto cardstock. Cut the sheet into the 4 individual QR Code cards. Distribute 1 of these individual QR Code cards to each learner.
- Find **K RECIPE CARD RESOURCE SHEET 41** on page 10 and print onto cardstock. Cut the sheet in half into individual recipe cards. Distribute 1 recipe card to each learner.
- Order each of the ingredients in the recipe: unsweetened baking cocoa (Dutched/Dutch processed preferred), sugar (OR sugar-substitute such as Stevia), salt, powdered nonfat milk, mini marshmallows. Pour/place the following amount of each ingredient into its own snack size zipper-seal bag and distribute 1 of each bag to each learner:
 - 4 tablespoons of unsweetened baking cocoa (Dutched/Dutch processed preferred)
 - 4 tablespoons of sugar (OR sugar-substitute such as Stevia)
 - 2 pinches of salt
 - 2/3 cup of powdered nonfat milk
 - A handful of mini marshmallows
 - NOTE: You will need to distribute more salt to learners in this module for Week 5. Learners will need 3 teaspoons each. Keep this in mind when you order salt.

Week 2

- QR code card, printed on cardstock, leading to the explanation video for children
- 1 sheet of *K'hillah* Roles, printed on regular paper (see Prep Instructions)
- Yarn (approx. 9 yards – see Prep Instructions)
- Chunk of sticky-tack (enough for the 6 stakes – see Prep Instructions)
- 6 six-inch garden stakes
- If adapting to an indoor version of this activity (see Prep Instructions):
 - 1 twelve-inch flat Styrofoam circle or square
- 2 zipper-seal bags (snack size)
 - 1 for the yarn
 - 1 for the sticky-tack

Prep Instructions:

- **IMPORTANT:** Decide if you are going to send this activity as an indoor or outdoor activity. The indoor activity requires the extra Styrofoam piece.
- Find **K QR W2 RESOURCE SHEET 42** on page 11 and print onto cardstock. Cut the sheet into the 4 individual QR Code cards. Distribute 1 individual QR Code cards to each learner.
- Find **K ROLES RESOURCE SHEET 43** on page 12 and print onto regular paper. Cut the sheet into individual sets of roles (X roles per set) and distribute 1 set to each learner.
- Order yarn (any color and any brand). Cut the yarn into approx. 9-yard pieces and ravel the piece around your hand into a circle. Place 1 circle of yarn into a snack size zipper-seal bag and distribute 1 bag of yarn to each learner.
- Order sticky-tack (any brand). Break it into chunks large enough for learners to stick a role card to each of the 6 stakes with the ability to interchange roles (while learners will reuse stick-tack pieces, provide enough extra just in case) and place 1 chunk into a snack size zipper-seal bag. Distribute 1 bag of sticky-tack to each learner.
- 6" garden stakes. Distribute 6 stakes to each learner.
- FOR INDOOR VERSION: Order 12" flat Styrofoam circles or squares. Distribute 1 Styrofoam shape to each learner.

Week 3

- **FOR TEACHER** (see Prep Instructions)
Per each learner in the teacher's *k'vutzah*:
 - 1 "For Teachers" Card
 - 1 self-sealing envelope
 - 1 stamp per learner in the *k'vutzah*
- QR code card, printed on cardstock, leading to the explanation video for children
- Shabbat Blessings card, printed on cardstock
- 1 sheet Shalom card decorating images, printed on regular paper
- 2 White Shabbat Candles, taper style
- 3 colors of modeling wax (see Prep Instructions)
- 1 folding tent card with a self-sealing envelope (**PLUS** – enough FOR TEACHERS – see Prep Instructions)
- 1 stamp (see Prep Instructions)
- 1 glue stick
- 2 zipper-seal bags (snack size)
 - 1 for the candles
 - 1 for the modeling wax

Prep Instructions:

- **FOR EACH TEACHER** –
 - Find **K FOR TEACHERS RESOURCE SHEET 44** on page 13 and print onto regular paper. Provide each teacher with enough copies to have 1/learner in their *k'vutzah*, plus a few extras for potential errors.
 - Optional: Pre-cut these sheets for teachers 😊
 - Order (if necessary) self-sealing envelopes and stamps. Distribute both to every teacher, enough for each learner in the teachers' *k'vutzot*.
 - NOTE: You will also need self-sealing envelopes and stamps for each learner, to be distributed into their boxes, as well.
- Find **K QR W3 RESOURCE SHEET 45** on page 14 and print onto cardstock. Cut the sheet into the 4 individual QR Code cards. Distribute 1 individual QR Code cards to each learner.
- Find **K BLESSING CARD RESOURCE SHEET 46** on pages 15-18. Pick which Shabbat Blessings card version you'd like to use.
 - If you have your own organizational version of a blessings card, please feel free to use that and distribute 1 to each learner.
 - If you'd like to use one of ours, once you've picked one, print it onto cardstock and distribute 1 card to each learner.
- Find **K CARD DECORATION RESOURCE SHEET 47** on page 19 and print onto regular paper. Distribute 1 set of images to each learner.
- Order white Shabbat candles, taper style. Place 2 candles into a sandwich or quart size zipper-seal bag and distribute 1 bag of candles to each learner.
- Order modeling wax. Cut the wax strips into 2" long pieces. Place 3 different colored pieces into a sandwich size zipper-seal bag and distribute 1 bag of colored wax to each learner.
- Order blank folding tent cards along with self-sealing envelopes. Distribute 1 blank card and 1 blank envelope to each learner.
- Order stamps and distribute 1 stamp to each learner.
- Order (if necessary) a set of glue sticks and distribute 1 glue stick to each learner (also used in *Sukkat Shalom* Week 3 and *G'vurah* Week 3), so you may not need to order more).
 - Optional – You may request families reuse their glue stick from a previous module instead of distributing another one.

Week 4

- QR code card, printed on cardstock, leading to the explanation video for children
- 1 glow stick necklace (see Prep Instructions)
- 2+ colors of modeling or air-dry clay, approx. 1 oz of each color (see Prep Instructions)
- 1+ zipper-seal bag (snack size)
 - 1 for the glow stick necklace connector (optional)
 - 1+ of the clay
 - Depending on the clay, you may wish to put each color in its own bag

Prep Instructions:

- Find **K QR W4 RESOURCE SHEET 48** on page 20 and print onto cardstock. Cut the sheet into the 4 individual QR Code cards. Distribute 1 individual QR Code cards to each learner.
- Order glow stick necklaces. Distribute 1 glow stick necklace with its connector to each learner.
 - Optional: Place the glow stick connector into a snack size zipper-seal bag. Distribute 1 bag, along with the glow stick necklace to each learner.
- Order modeling or air-dry clay. Place approx. 1oz of 2 or more colors into snack size zipper-seal bag(s) and distribute 2+ colors of clay to each learner.
 - Depending on the type of clay you purchase and how it is packaged, you may wish to put each color into its own zipper-seal bag to keep the clay fresh. If clay is placed into separate zipper-seal bags, distribute 2+ bags of different colored clay to each learner. If you choose to put 2+ colors of clay all in 1 bag, then distribute 1 bag of 2+ colors of clay to each learner.

Week 5

- QR code card, printed on cardstock, leading to the explanation video for children
- 1 iron-on transfer – printed with *K'hillah* (see Prep Instructions)
- 1 organizational or plain swag item (that can accept the *k'hillah* template ironed onto it and can be washed in hot water – see Prep Instructions)
- 8 colors of tie-dye cords
- 1 pair of nitrile gloves
- 1 tie-dye cords directions sheet
- 3 teaspoons of salt
- 2 zipper-seal bags (snack size)
 - 1 for the tie-dye cords
 - 1 for the salt

Prep Instructions:

- Find **K QR W5 RESOURCE SHEET 49** on page 21 and print onto cardstock. Cut the sheet into the 4 individual QR Code cards. Distribute 1 of these individual QR Code cards to each learner.
- Find **K TRANSFER RESOURCE SHEET 50** on pages 22-23. Print the mirrored images on page 22 onto iron-on transfer paper. (For this activity to be successful you must print page 22 onto the transfer paper; page 23 is for your reference - DO NOT print this page onto the iron-on transfer paper.) Cut each page into the 2 individual images. Distribute 1 of these iron-on transfer images to each learner.
 - An iron-on transfer was also used in *Sukkat Shalom* Week 1, so you may not need to order more.
 - NOTE: You may choose to add your organization's logo to this image. If you do this, you MUST mirror the image before you print it onto iron-on transfer paper. To add your organization's logo to this image, you must first convert the included PDF into a photo format such as a JPEG or PNG file. Add your logo wherever you'd like it to this new image file. Once your logo is added to the *K'hillah* template, make sure you mirror the updated image however your computer allows you to mirror images. On a Mac, this is easily done in Preview. On a PC, you may need to put your updated image into a Word Document, and you can flip it in Word.

You may also wish to print your organization's logo on its own iron-on transfer. If this is the case, make sure to distribute BOTH iron-on transfers to each learner.

- Find **K TIE DYE DIRECTIONS RESOURCE SHEET 51** on page 24. Print onto regular paper OR cardstock and distribute 1 directions sheet to each learner.
 - Note: These are the directions that come with the tie-dye cords but only the first page. These are the directions used in the video in the W5 QR Code.
- Select and order an organizational or plain swag item that can that can accept the *k'hillah* template ironed onto it and can be washed in hot water (such as a t-shirt, canvas bag, bandana, etc.).
- Order tie-dye color cords. Place 8 cords, in a variety of colors, into a snack size zipper-seal bag and distribute 1 bag of cords to each learner.
- Order nitrile gloves. Distribute 1 pair of nitrile gloves to each learner.
- Order (if necessary) salt. Place 3 teaspoons of salt into a snack size zipper-seal bag and distribute 1 bag of salt to each learner.

Item	Total Number per Learner	Week Number	Amount per Week per Learner (if more than 1 week)
Unsweetened Baking Cocoa (Dutched/Dutch processed preferred) Such as: https://tinyurl.com/yykmyjvz	4 tablespoons (2oz)	1	
Sugar (OR sugar-substitute such as Stevia)	4 tablespoons (2oz)	1	
Salt	2 pinches 3 teaspoons	1 5	
Powdered Nonfat Milk Such as: https://tinyurl.com/y4dpezv7	2/3 cup	1	
Mini Marshmallows	A handful	1	
Sticky-tack Such as: https://tinyurl.com/yxlgj6sm	6 pieces (for labels to be attached to the 6 stakes)	2	
Garden stakes (around 6") Such as: https://tinyurl.com/y4uy4nuk	6 stakes	2	
OPTIONAL: Styrofoam block (around 12"x12"x1") Such as: https://tinyurl.com/y3lbbg3f	If doing an indoor version: 1	2	
White Shabbat Candles, taper-style Such as: https://tinyurl.com/y3z8en77	2	3	
Modeling Wax Such as: https://tinyurl.com/y3v22snn	3 colors	3	
Folding tent card with self-sealing envelope Such as: These folding tent cards - https://tinyurl.com/y6j2yd43 With these self-sealing envelopes – https://tinyurl.com/y546t5vw	1	3	
Tie Dye Cords Such as: https://tinyurl.com/y6symm8p	8 colored cords	5	
Glow Stick Necklaces Such as: https://tinyurl.com/y5yy9tnc	1	4	
Swag item from your organization or plain – That can accept the	1	5	

<i>k'hillah</i> template ironed onto it and can be washed in hot water (Ex: T-shirt, canvas bag, bandana, etc.)			
Clay – Modeling or Air Dry	2+ colors, approx. 1oz of each color	4	
Yarn	Approx. 3 yards	2	
Iron-on transfer (also used in <i>Sukkat Shalom</i> Week 1)	1	5	
Zipper-seal Bags Snack Size	12 bags total (possibly more)	1-5	Week 1: 5 bags Week 2: 2 bags Week 3: 2 bags Week 4: 1+ bag(s) Week 5: 2 bags
Cardstock	2.75 sheets	1-5	Week 1: ¾ sheet Week 2: ¼ sheet Week 3: 1 ¼ sheets Week 4: ¼ sheet Week 5: ¼ sheet
Copy Paper	2 sheets	2, 3	Week 2: 1 sheet Week 3: 1 sheet

K'hillah

Place 1 label on each box/bag/kit.

Place 1 label on each box/bag/kit.

קהלה



k'hillah

social connectedness
&
community

קהלה



k'hillah

social connectedness
&
community

Place 1 label on each box/bag/kit.

Place 1 label on each box/bag/kit.

קהלה



k'hillah

social connectedness
&
community

קהלה



k'hillah

social connectedness
&

K W1 QR CODE



K'hillah

HOT CHOCOLATE

This makes 1 cup of hot chocolate

INGREDIENTS

- 2 tablespoons unsweetened cocoa powder
- 1 to 2 tablespoons sugar (or sugar substitute)
(depending on how sweet you like it)
- Pinch of salt
- 1/3 cup powdered milk
- 1 cup hot water
- marshmallows

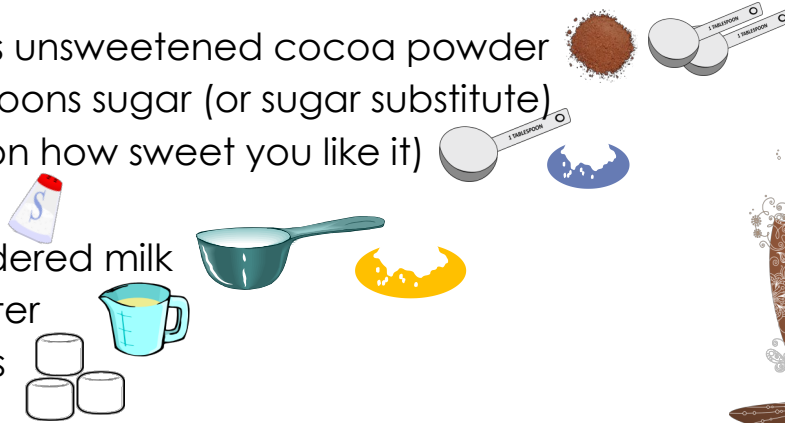

PREPARATION

1. In a cup, mix together the cocoa, sugar, salt and powdered milk.
2. With the help of an adult, slowly add 1 cup of hot water. Stir to mix all the ingredients.
3. Top with marshmallows and ENJOY!!



HOT CHOCOLATE

This makes 1 cup of hot chocolate

INGREDIENTS

- 2 tablespoons unsweetened cocoa powder
- 1 to 2 tablespoons sugar (or sugar substitute)
(depending on how sweet you like it)
- Pinch of salt
- 1/3 cup powdered milk
- 1 cup hot water
- marshmallows

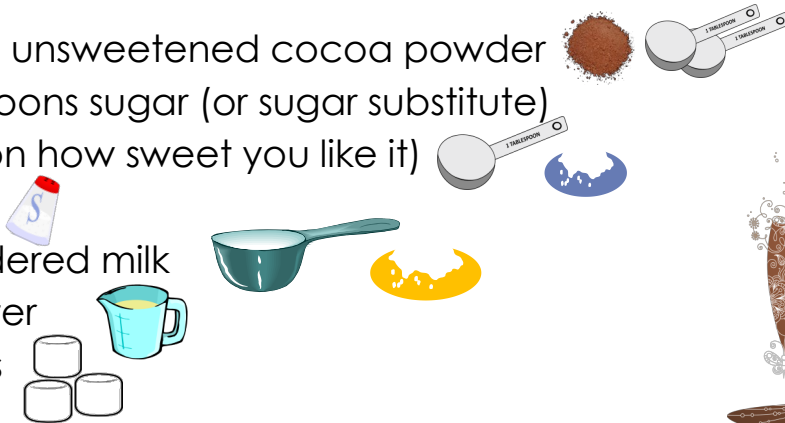

PREPARATION

1. In a cup, mix together the cocoa, sugar, salt and powdered milk.
2. With the help of an adult, slowly add 1 cup of hot water. Stir to mix all the ingredients.
3. Top with marshmallows and ENJOY!!



K W2 QR CODE



K'hillah

Labels for the stakes - attach one label to each stake.



K'hillah

For the teacher: Cut the rectangle. Fold it in half top to bottom and in half right to left. Write a message, put it in an envelope and send a card to each of your learners.



K W3 QR CODE



SHABBAT BLESSINGS



Blessing over the Candles

בָּרוּךְ אַתָּה יְיָ, אֱלֹהֵינוּ מֶלֶךְ הָעוֹלָם, אֲשֶׁר קִדְּשָׁנוּ בְּמִצְוֹתָיו,
וְצִוָּנוּ לְהַדְלִיק נֵר שֶׁל שַׁבָּת.

*Baruch atah Adonai, Eloheinu Melech ha'olam, asher kid'shanu b'mitzvotav,
v'tzivanu l'hadlik ner shel Shabbat.*

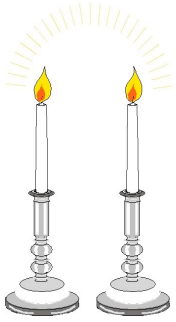

Blessed are you Adonai our God, Ruler of the universe,
who has made us holy through God's commandments,
and commanded us to light the Sabbath candles.

Kiddush - Blessing over the wine

בָּרוּךְ אַתָּה יְיָ, אֱלֹהֵינוּ מֶלֶךְ הָעוֹלָם, בּוֹרֵא פְּרֵי הַגָּפֶן.

Baruch atah Adonai, Eloheinu Melech ha'olam, borei p'ri hagafen.

Blessed are you Adonai our God, Ruler of the universe
who creates the fruit of the vine.

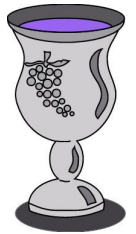

Blessing over the Hallah

בָּרוּךְ אַתָּה יְיָ, אֱלֹהֵינוּ מֶלֶךְ הָעוֹלָם, הַמוֹצִיא לֶחֶם מִן הָאָרֶץ.

Baruch atah Adonai, Eloheinu Melech ha'olam, hamotzi lechem min ha'aretz.



Blessed are you Adonai our God, Ruler of the universe,
who causes bread to come forth from the earth.

Blessing for our Children

יְבָרְכֶךָ יְיָ וַיְשַׁמְרֶךָ. יָאֵר יְיָ פָּנָיו אֵלֶיךָ וַיַּחֲנֶנֶךָ.
יִשָּׂא יְיָ פָּנָיו אֵלֶיךָ וַיִּשֵׂם לְךָ שָׁלוֹם.

*Y'varech'cha Adonai v'yish'm'recha. Ya'eir Adonai panav eilecha viy'huneka.
Yisa Adonai panav eilecha, v'yasem lecha shalom.*



May God bless you and protect you. May God shine upon you and be
gracious to you. May God always be with you and grant you peace.



SHABBAT BLESSINGS



Blessing over the Candles

בְּרוּךְ אַתָּה יְיָ, אֱלֹהֵינוּ מֶלֶךְ הָעוֹלָם, אֲשֶׁר קִדְּשָׁנוּ בְּמִצְוֹתָיו,
וְצִוָּנוּ לְהַדְלִיק נֵר שֶׁל שַׁבָּת.

*Baruch atah Adonai, Eloheinu Melech ha'olam, asher kid'shanu b'mitzvotav,
v'tzivanu l'hadlik ner shel Shabbat.*



Blessed are You, Adonai our God, Ruler of the universe,
who has made us holy through God's commandments,
and commanded us to light the Sabbath candles.

Blessing for our Children

יְשִׁמַּח אֱלֹהִים כְּסָרָה,
רִבְקָה, רָחֵל, וְלֵאָה



*Y'simeich Elohim k'Sarah,
Rivkah, Rachel v'Leah*

May God inspire you to live in the
tradition of Sarah and Rebekah,
Rachel and Leah, who carried
forward the life of our people.

יְשִׁמַּח אֱלֹהִים כְּאֶפְרַיִם
וְכִמְנַשֶּׁה



*Y'Simcha Elohim k'Efrayim
v'chiManasheh.*

May God inspire you to live in the
tradition of Ephraim and Manasseh,
who carried forward the life
of our people.

יְבָרְכֶךָ יְיָ וַיְשִׁמְרֶךָ. יָאֵר יְיָ פָּנָיו אֵלֶיךָ וַיְחַנְּךָ.
יֵשָׂא יְיָ פָּנָיו אֵלֶיךָ וַיִּשֶׂם לְךָ שְׁלוֹם.

*Y'varech'cha Adonai v'yish'm'recha. Ya'eir Adonai panav eilecha viy'huneka.
Yisa Adonai panav eilecha, v'yasem lecha shalom.*

May God bless you and protect you. May God shine upon you and be
gracious to you. May God always be with you and grant you peace.

Kiddush - Blessing over the Wine

וַיְהִי עֶרֶב וַיְהִי בֹקֶר יוֹם הַשְּׁשִׁי.

Vay'hi erev vay'hi voker yom hashishi.

And there was evening and there was morning, the sixth day.

וַיְכַלּוּ הַשָּׁמַיִם וְהָאָרֶץ וְכָל צְבָאָם. וַיְכַל אֱלֹהִים בַּיּוֹם הַשְּׁבִיעִי
מְלַאכְתּוֹ אֲשֶׁר עָשָׂה, וַיִּשְׁבֹּת בַּיּוֹם הַשְּׁבִיעִי, מִכָּל מְלַאכְתּוֹ אֲשֶׁר עָשָׂה.
וַיְבָרֶךְ אֱלֹהִים אֶת יוֹם הַשְּׁבִיעִי וַיְקַדֵּשׁ אֹתוֹ, כִּי בּו שָׁבֹת
מִכָּל מְלַאכְתּוֹ, אֲשֶׁר בָּרָא אֱלֹהִים לַעֲשׂוֹת.

*Vay'chulu hashamayim v'haaretz v'chol tzva'am. Vay'chal Elohim bayom hashvi'i
m'lachto asher asah, vayishbot bayom hashvi'i, mikol m'lachto asher asah.
Vay'vareich Elohim et yom hashvi'i vay'kadeish oto, ki vo shavat
mikol m'lachto, asher bara Elohim la'asot.*

The heaven and the earth were finished, and all of their array. On the seventh day, God finished the work that God had been doing, and God ceased on the seventh day from all the work that God had done. And God blessed the seventh day and declared it holy, because on it God ceased from all the work of creation that God had done.

בָּרוּךְ אַתָּה יְיָ, אֱלֹהֵינוּ מֶלֶךְ הָעוֹלָם, בּוֹרֵא פְּרֵי הַגָּפֶן.

Baruch atah Adonai, Eloheinu Melech ha'olam, borei p'ri hagafen.

Blessed are You, Adonai our God, Ruler of the universe
who creates the fruit of the vine.

בָּרוּךְ אַתָּה יְיָ, אֱלֹהֵינוּ מֶלֶךְ הָעוֹלָם,
אֲשֶׁר קִדְּשָׁנוּ בְּמִצְוֹתָיו וְרָצָה בָּנוּ

*Baruch atah Adonai, Eloheinu Melech ha'olam,
asher kid'shanu b'mitzvotav v'ratzah vanu*

Praised are You, Adonai our God, Ruler of the world, who makes us
holy with commandments and takes delight in us.

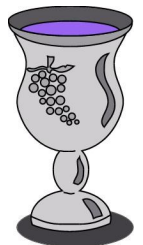

וְשַׁבַּת קֹדֶשׁוֹ בְּאַהֲבָה וּבְרָצוֹן הִנְחִילָנוּ, זְכוֹר לְמַעֲשֵׂה בְּרֵאשִׁית.
כִּי הוּא יוֹם תְּחִלָּה לְמִקְרָאֵי קֹדֶשׁ, זְכוֹר לִיציאת מִצְרָיִם.
כִּי בָנוּ בְּחֵרְתָּ וְאוֹתָנוּ קִדְשָׁתָּ מִכָּל הָעַמִּים, וְשַׁבַּת קֹדֶשְׁךָ בְּאַהֲבָה
וּבְרָצוֹן הִנְחִלְתָּנוּ. בָּרוּךְ אַתָּה, יְיָ מִקְדֵּשׁ הַשַּׁבָּת.

v'Shabbat kodsho b'ahavah uv'ratzon hinhilanu, zikaron l'ma'aseih v'reishit.

Ki hu yom t'hilah l'mikra-ei kodesh, zecher litzit'at Mitzrayim.

*Ki vanu vaharta, v'otanu kidashta, mikol ha'amim. V'Shabbat kodsh'cha b'ahavah
uv'ratzon hinhaltanu. Baruch atah, Adonai, m'kadeish haShabbat.*

In love and favor, God has made the holy Shabbat,
our heritage, as a memory of the work of creation. It is first among our holy days,
a memory of going out from Egypt. You chose us from all other nations and
You made us holy, and with love and favor
You have given us the Shabbat as a holy inheritance.
Praised are You, Adonai, who makes Shabbat holy.

Blessing over the Hallah

בָּרוּךְ אַתָּה יְיָ, אֱלֹהֵינוּ מֶלֶךְ הָעוֹלָם, הַמוֹצִיא לֶחֶם מִן הָאָרֶץ.

Baruch atah Adonai, Eloheinu Melech ha'olam, hamotzi lehem min ha'aretz.

Blessed are you, Adonai our God, Ruler of the universe,
who causes bread to come forth from the earth.



K'hillah

Make a card for your friend. You can use these pictures or draw your own pictures.

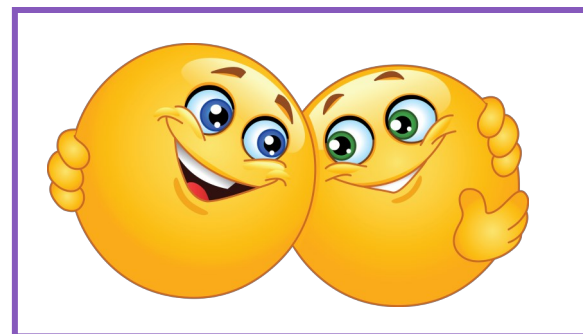

K W4 QR CODE



K W5 QR CODE



K'hillah



Iron-on transfer
(mirror image)

Iron-on transfer
(mirror image)



K'hillah



Iron-on transfer



Iron-on transfer

Basic Dying Instructions A Marbleizing effect

Materials Needed:

- Gloves
- Apron
- 2-3 Quarts of Water
- Pan to hold 2-3 qts. of water
- Color cords
- T-Shirt
- Elastic Bands
- 3 Teaspoons Salt
- Large mixing bowl
- Large Zipper seal bag

- 1) Lay fabric flat.
- 2) Cut cords to desired lengths & place cords on shirt where you want that color to be. (If you prefer, secure cord ends with tape)
- 3) **Begin folding in each edge of fabric in turn (fold top once, then left side, then right, keep going around) about 2 to 3 inches each fold until all edges are folded into the center to form a bundle.**
- 4) **Secure bundle well with rubber bands or twine.**
- 5) **In large mixing bowl place 3 teaspoons of salt in Very Warm water.**
- 6) **Submerge bundle into mixing bowl with salted water, allow water to penetrate through the bundle.**
- 7) **Gently squeeze out excess water.**

Tip: how hard or soft you squeeze will determine how far the dye will bleed from the cords, affecting your design .

- 8) Place wet bundle in a zipper seal bag.
- 9) Drop bag into boiling water & boil for 20 minutes.
- 10) Carefully place bag in sink to cool.
- 11) **When cool, unwrap, remove cords rinse thoroughly & dry.**
You're done. The first 2 wash/dry cycles should be done separately.

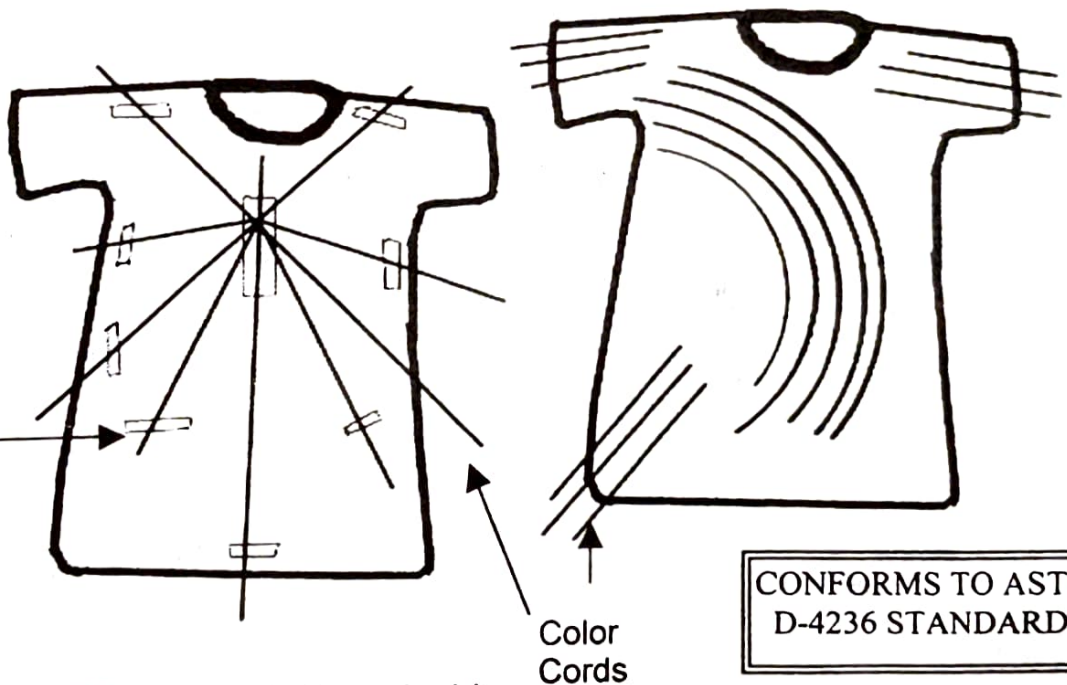

Additional Dying instructions inside

Adult supervision required. Dyes are permanent & will stain surfaces. Work area should be protected. Wear protective gloves and apron. Use a poly cotton blend for best results. Item must be washed & dried once before dyeing. Nontoxic dyes, Not for consumption. If swallowed seek medical advice.